

Welcome to PowerNet Software



Version 2.30

from



Copyright © 2010-2012 Megasy's Software
All rights reserved.

Table of Contents

Getting Started

Quick start.....	3
Using PoweNet.....	4
Keyboard Shortcuts	5
Mouse Techniques.....	6

Menus

File menu commands.....	7
Edit menu	8
View Menu.....	9
Circuit Menu	10
Device Menu	11
Symbols Menu	12
Graphics Menu	13
Window menu.....	14
Help menu.....	15
Toolbars	16
Main Toolbar.....	17
Circuit Toolbar	18
Graphics Toolbar	19
Symbols Toolbar	20
Symbol Set Toolbar	21

Overview

Circuits	22
Devices.....	23
Symbols	24
Grids and Lines	25
Abbreviations.....	26

Building Circuits

The Symbols Bar	20
Manipulating Symbols.....	28
Drawing connecting lines.....	29
Copying and pasting symbols.....	30
Positioning symbol labels	31

Graphics

Graphics Elements.....	32
Graphics Operations	33
Graphics Properties	34

Entering Data

General Info	35
Options	36
Device Database	37
Source Bus	38
Cable.....	39
Capacitor	41
Generator	42
Loads	44
Induction Motor	45

Synchronous Motor	46
Protective Device	48
Transformer.....	49
Transmission Line	51
Impedance	52
Calculation	
Overview	53
Analysis.....	54
Load Flow.....	55
Fault	56
Displaying Results	
Electrical Data.....	58
Data Tip Window.....	59
Device Meter Bar.....	60
Vector Display.....	61
Circuit Report.....	62
Customizing PowerNet	
Units Settings	63
Folders	64
Colour	65
Fonts.....	66
Printer	67
Circuit Default.....	68
Calculation & Data.....	69
License and Ordering Information	
EULA	70
How To Oder	71
License Key	72
Technical Support	
Feedback.....	73
Upgrades.....	74

Quick Start

The quickest way to get up and running in using PowerNet is to open the sample circuit files provided with the installation. These are normally located in the *Circuits* folder under your documents folder.

- Familiarise yourself with the function of the [toolbar](#) buttons by slowly mousing over them while watching tool tips and the status bar messages. Do the same with the symbols on the symbols toolbar.
- If the circuit is not active, click on the calculate button . The circuit will be analyzed and calculated. The [meter bar](#) should then appear. Mouse over the circuit diagram symbols and lines to display [data tips](#). Click on any symbol or connecting line to display electrical data on the meter bar and device info on the status bar.
- Try moving individual lines and symbols by left clicking on them and dragging them to different screen positions. Try copying them by holding down the [Ctrl] key and dragging the symbols or lines to another position.
- Add a new symbol by selecting a symbol from the [symbols toolbar](#) and clicking on an empty area on the screen.
- Add a new line by mousing over a snap grid position until the cursor turns to crosshair. Left click and drag the cursor to the desired end point.
- Double click on a circuit diagram symbol to bring up the device properties pages. Modify the device data, calculate the circuit and observe the effect on the electrical data.

If you encounter any difficulties doing any of the above, please refer to the appropriate section of this help file.

Using PowerNet

The use of PowerNet consists of three basic steps:

1. Drawing the circuit diagram.
2. Entering data for all devices in the diagram.
3. Calculating the circuit.
4. Displaying the result.

Drawing the Circuit Diagram.

The circuit can be any actual circuit consisting of standard electrical devices and equipment such as cables, loads, generators, motors, etc. The circuit is represented by drawing symbols and connecting lines on the screen circuit display area. The result is a single line diagram.

To draw a symbol, click on a symbol button on the [symbols bar](#). Move the mouse cursor to the desired position on the screen and click to draw the symbol.

Connecting lines are started by positioning the mouse cursor on a grid point where it turns into a cross-hair cursor. Click and hold the left mouse button and move to the desired endpoint. Note that lines may only be drawn between snap grid points. Snap grids may be displayed by clicking on the Snap Grid Button.

Connecting lines may only be drawn as vertical or horizontal lines. When crossing over other lines, the line being drawn automatically crosses over (no connection) the other line. To cross-connect, terminate the line on the other line.

Entering Data.

Data for all the symbols must be entered before circuit analysis may be performed. To enter data for a device, double click on the symbol. This will activate a Data Entry Form. Most of the data entry fields in this form are required, although some, such as the Label and Description fields are not.

A useful feature of PowerNet is the [Device Database](#). By clicking on the [DATABASE] button in the Data Entry Form, a Database Selection Panel is activated. By clicking on menu drop down lists and selecting from the main list, the data entry fields on the Data Entry Form are automatically filled in. Of course, some fields such as cable lengths must still be filled in manually.

Another useful feature is the [AutoFill] button. Clicking this button automatically fills in the data entry form with values copied from the last saved data entry form.

Calculation.

Calculation is started by selecting CIRCUIT|CALCULATE from the menu or clicking on the [Calculate] button on the [Circuit Toolbar](#). This will start the analysis and error checking process.

When the calculation is completed, the circuit is said to be *active*.

Display Result.

Electrical data can be displayed using the device meter bar and the vector display panel. Select any symbol by clicking it to show voltages, current kva, kw and power factor on the meter toolbar and voltage and current vector on the vector display panel. Hover the mouse on any part of the circuit to show device info and electrical data in a [data tip window](#).

A [text report](#) on the circuit can be displayed on screen. The report can be saved in *rich text format (RTF)* or *Microsoft Word Format (DOC)* which can be read in Microsoft Word or most other word processing software for further formatting and editing.

Keyboard Shortcuts

Following are tables of keyboard shortcuts. Many of the shortcuts can speed up PowerNet operations like zooming the circuit display.

Edit Operations

<i>Menu</i>	<i>Keyboard</i>	<i>Action</i>
Copy	Ctrl+C	Copy object to clipboard
Cut	Ctrl+X	Delete object and save to clipboard
Paste	Ctrl+V	Paste object from clipboard
Undo	Alt+BkSp	Reverse the last operation

Common Operations

<i>Menu</i>	<i>Keyboard</i>	<i>Action</i>
Circuit Report	Ctrl+R	View circuit report
Circuit Calculate	F8	Calculate circuit.
Device Data	Enter	Show device data
View Grid	Ctrl+G	Toggle Grid display
Help	F1	Display help
Close Window	Alt+F4	Close current window

Zoom Operations

<i>View Command</i>	<i>Keyboard</i>	<i>Action</i>
Zoom In	[+]	Increase magnification
Zoom Out	[-]	Decrease magnification

Mouse Techniques

In addition to the standard functions of the mouse in Windows, there are several additional functions of the mouse in PowerNet.

Device Information - Clicking on a symbol will display device information on the Status Line. A double click on the symbol activates a Device Information Box that displays more detailed information on the device if the circuit is active. Hover the mouse button over a symbol or connecting line to display a data tip window.

Entering or Editing Device Data - If the circuit is inactive (has not been calculated or has just been edited), a double click on the symbol activates a Data Entry Form for filling in or editing device ratings. Otherwise, a Device Information Box will be displayed.

Device Selection - A left click on a device symbol selects that device and draws a gray rectangle around it. A small rectangle is also drawn on the head connection end of the symbol to differentiate it from the tail end. To select a group of device symbols, hold the shift key while clicking each symbol in turn.

Drawing Symbols - Select a symbol from the symbols toolbar by clicking on a symbol button. Then move the mouse to the desired grid location on the screen. Note that the cursor shape changes to indicate the symbol orientation depending on the position of the cursor relative to the snap grid point. Left click the mouse button to add the symbol to the circuit diagram.

Drawing Connecting Lines - Mouse-over a grid position changes the cursor to cross-hairs. Clicking on the snap grid position and dragging the mouse cursor across the screen produces a rubber banding line. Releasing the mouse button draws a connecting line.

Group Selection - A selection box may be started by clicking on a space away from snap grid positions. Holding the left mouse button while dragging the mouse across produces a rubber banding selection box. Releasing the mouse button will select all devices, lines and graphics objects inside the box. Also, holding the [SHIFT] key while clicking on several symbols in turn will select the symbols.

Moving a Symbol or Group - Clicking on any selected symbol and dragging the mouse cursor across the screen before releasing the mouse button will move the symbol or group of symbols to the new position. Note that symbols may not be moved to a position that is already occupied by another symbol.

Duplicating a Symbol or Group - Pressing the [CONTROL] key while clicking on a selected symbol and dragging the mouse cursor across the screen before releasing the mouse button will copy the symbol or group of symbols to the new position. Note that symbols may not be copied to a position that is already occupied by another symbol or line.

File menu commands

The File menu offers the following commands:

New	Creates a new document.
Open	Opens an existing document.
Close	Closes an opened document.
Save	Saves an opened document using the same file name.
Save As	Saves an opened document to a specified file name.
Print	Prints a document.
Print Preview	Displays the document on the screen as it would appear printed.
Print Setup	Selects a printer and printer connection.
Send...	Sends the active circuit document through electronic mail.
Exit	Exits PowerNet.

Edit menu commands

The Edit menu offers the following commands:

Undo	Reverse previous editing operation.
Cut	Deletes data from the document and moves it to the clipboard.
Copy	Copies data from the document to the clipboard.
Paste	Pastes data from the clipboard into the document.
Delete	Pastes from the clipboard a link to data in another application.
Select All	Selects all connecting lines, symbols and graphics.
Default Settings	Opens settings box for PowerNet default settings.

View menu commands

The View menu offers the following commands:

Symbols Bar	Shows or hides the toolbar.
Status Bar	Shows or hides the status bar.
Grid	Shows or hides the screen grid.
Zoom In	Increase screen magnification.
Zoom Out	Decrease screen magnification.
Toolbar s	Shows or hides devices , graphics , meter , symbols and symbol set toolbars
Vectors	Display voltage/current vector diagram for selected device

Circuit menu commands

The Circuit menu offers the following commands:

Report	Generates a text report for this circuit.
Symbol Set	Select a symbol set file.
Fault	Simulate a fault on the circuit.
Calculate	Calculates the electrical circuit.
Properties	Opens a circuit properties dialog box.

Device menu commands

The Device menu offers the following commands:

Properties	Opens device properties settings box.
Edit Symbol Graphics	Edit selected circuit symbol in-place.
Rotate Clockwise	Rotate symbol clockwise.
Rotate Counter-clockwise	Rotate symbol counter-clockwise.
Invert	Invert symbol head to tail
Disconnect	Connects/Disconnects the selected device.

Symbols Menu

The Symbols Menu offers the following commands:

Next Set	Display the next set of symbols
Previous Set	Display the previous set of symbols
Insert New	Insert a new symbol to the left of the selected symbol
Delete	Delete the selected symbol
Properties	Edit the properties of the selected symbol
Copy to Memory	Copy the selected symbol to memory buffer
Paste from Memory	Paste the symbol in the memory buffer to the selected position
Copy from Circuit	Copy the selected circuit symbol to the symbols bar
Save Symbol Set	Save modified symbol set to file.

The symbols menu provide a way of modifying the symbol set within PowerNet. The above operations in conjunction with [Device/Edit symbol Graphics] menu are all that is needed to create and customise the symbol set to your preferences.

Graphics menu commands

The Graphics menu offers the following commands:

Select	Use selection tool.
Line	Draw line tool.
Rectangle	Draw rectangle tool.
Round Rectangle	Draw rounded rectangle tool.
Ellipse	Draw ellipse tool.
Pie	Draw elliptical pie tool.
Arc	Draw elliptical arc tool.
Chord	Draw elliptical chord tool.
Polygon	Draw polygon tool.
Polyline	Draw polyline tool.
Text	Draw text tool.
Arrange	Group/ungroup selections. Move selected graphics layer forward/backward.

See also:

[Graphics Toolbar](#)

Window menu commands

The Window menu offers the following commands, which enable you to arrange multiple views of multiple documents in the application window:

New Window	Creates a new window that views the same document.
Cascade	Arranges windows in an overlapped fashion.
Tile	Arranges windows in non-overlapped tiles.
Arrange Icons	Arranges icons of closed windows.

Help menu commands

The Help menu offers the following commands, which provide you assistance with this application:

Help Contents	Offers you an index to topics on which you can get help.
Help Index	Offers you an index to topics on which you can get help.
Buy Now	Opens the default internet browser to the PowerNet products page.
Enter License Key	Opens an entry form for the activation key.
Check for updates/Check Now	Check for new versions of Powernet
Check for updates/Check on start-up	Check for new versions of Powernet on starting up.
About	Displays the current version number of the installed Powernet software.

Toolbars

Use this command for instructions about using Help.

Main Toolbar





 New File - create a new circuit file.

 Open File - open an existing circuit file.

 File Save - save the current circuit file.

 Edit Cut - cut the selected object and save to Windows clipboard.

 Edit Copy - copy the selected object and save to Windows clipboard.









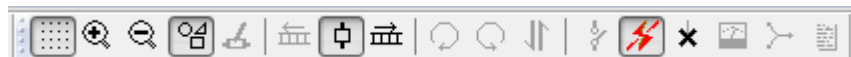







 Edit Paste - copy the saved object in Windows clipboard to the current circuit.

 File Print - print the current circuit diagram.

 Help About - display PowerNet copyright and version information.

Circuit Toolbar



-  Snap grids - show/hide snap grid points.
-  Zoom In - increase screen magnification.
-  Zoom out - decrease screen magnification.
-  Graphics - show/hide graphics toolbar.
-  Edit symbol - edit in-place the selected circuit symbol .
-  Next symbols - display next group of symbols on the toolbar.
-  Symbols - show/hide symbols toolbar.
-  Previous symbols - display previous group of symbols.
-  Rotate clockwise - rotate selected symbol clockwise.
-  Rotate counter-clockwise - rotate selected symbol counter-clockwise.
-  Invert - invert selected symbol head-tail.
-  Disconnect - disconnect the selected device from the circuit.
-  Calculate - show/hide electrical data/load flow for the circuit.
-  Fault - simulate a fault on the circuit.
-  Meter bar - show/hide meter bar. Only available if circuit is active.
-  Vector display - show/hide vector display panel. Only available if circuit is active.
-  Circuit Report - generates and display circuit report. Only available if circuit is active.

Graphics Toolbar



 Selection tool

 Line

 Rectangle

 Rounded rectangle

 Ellipse

 Elliptical Arc

 Elliptical Pie

 Elliptic chord

 Filled polygon

 Polyline

 Text

 Move selection forward one layer

 Move selection backward one layer

 Move selection to front-most layer



 Move selection to rear-most layer

 Group selection - consolidates all selected graphics to one unit

 Un-group selection - breaks down graphics to original components

Using the symbols toolbar



Use the symbols button  to show or hide the symbols toolbar. The next symbols group button  and previous symbol group button  selects the symbol group to display on the symbols toolbar.

Hover the mouse over any of the symbols on the toolbar to display the device class or type on the status bar.

Select a symbol by clicking on a symbol button, then move the mouse to the desired grid location on the screen. Note that the cursor shape changes to indicate the symbol orientation depending on the position of the cursor relative to the snap grid point. Left click the mouse button to add the symbol to the circuit diagram.

A symbol must be selected to enable editing the symbol set using the [symbol set toolbar](#).

Symbol Set Toolbar





 Display the next set of symbols

 Display the previous set of symbols

 Insert a new blank symbol to the left of the selected symbol

 Delete the selected symbol

 Edit the [properties](#) of the selected symbol

 Copy the selected symbol to memory buffer

 Paste the symbol in the memory buffer to the selected position

 Copy the selected circuit symbol to the symbols bar

The symbols set toolbar buttons provide a way of modifying the symbol set within PowerNet. The above operations in conjunction with symbol graphics edit operation  are all that is needed to create and customise the symbol set to your preferences.

Circuits

Circuit as used in PowerNet is a single line diagram representing a physical circuit. There must be at least one source (either a generator or a source bus), and one or more passive device (say, a load or a cable). All branches should preferably be terminated through a load, although PowerNet will still correctly analyze the circuit as long as some of the branches are correctly terminated. All devices in the circuit must be interconnected into one circuit, either through other devices or through connecting lines. Two or more independent (not interconnected) circuits are not allowed.

An example of a circuit:

Sample Building Services Diagram

Sample circuit illustrates a high rise building electrical distribution system. Normal power is supplied through a 33 kV source bus through a substation to the main switchboard. Standby power is supplied by a diesel standby generator which can also be run in parallel to the main bus. It will take less than an hour for a beginner to draw this diagram. An experienced user can draw the diagram, enter all device data, and calculate the circuit in 1 hour.

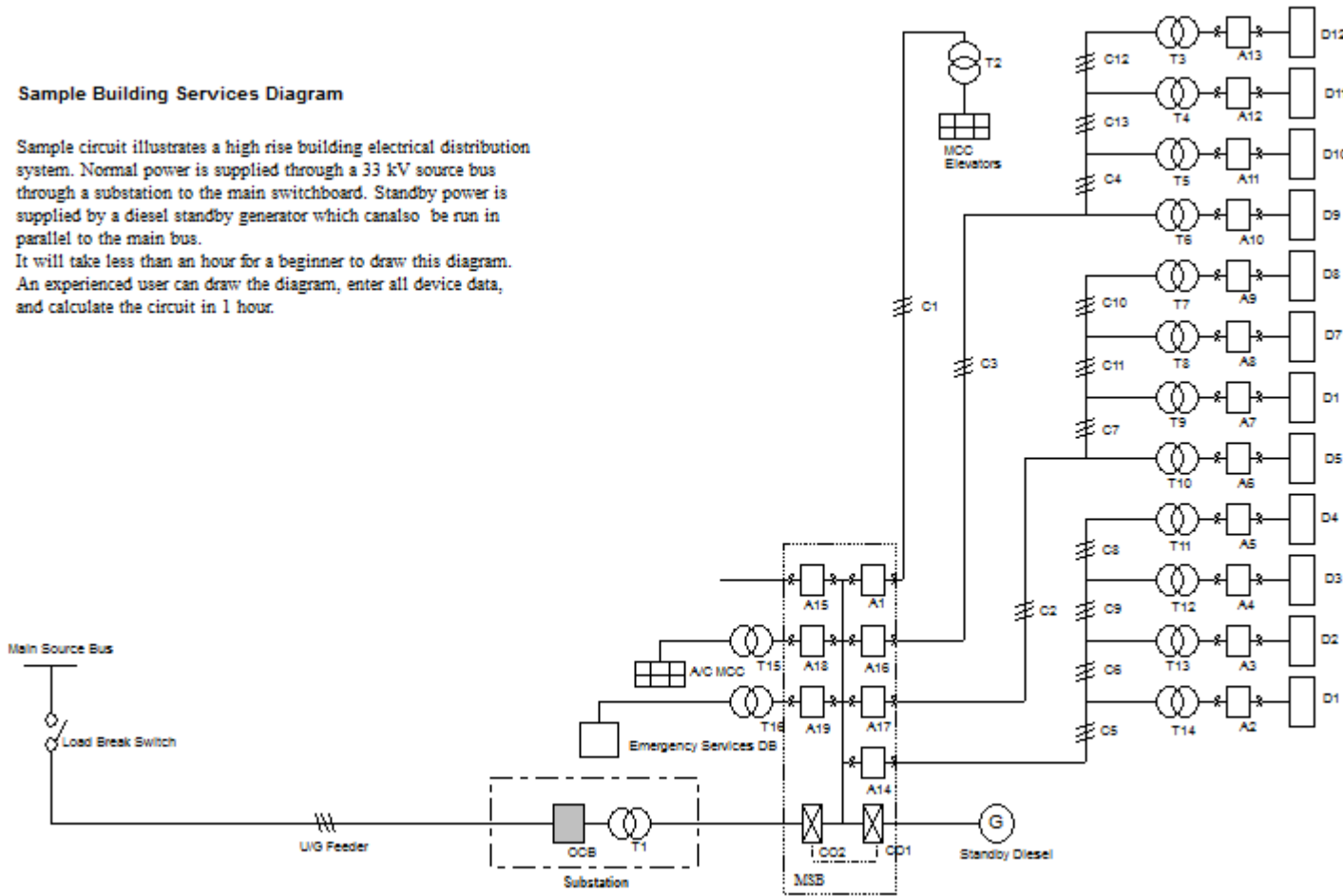

Devices

Device as used in PowerNet means any electrical equipment, circuit element or component. The device is represented in the circuit as a symbol. The device must be balanced, passive or active and must not be coupled either capacitively or inductively with other devices in the circuit. The symbol may be single-ended (3 terminals for three phase) or double ended(6 terminals) excluding the neutral.

All devices have three optional properties, name, label and description . The label and name may optionally be shown on the screen and on the circuit printout.

Devices are classified as follows:

SOURCE BUS

GENERATOR

CABLE

TRANSMISSION

IMPEDANCE

LOAD

INDUCTION MOTOR

SYNCHRONOUS MOTOR

POWER CAPACITOR

TRANSFORMER

PROTECTIVE DEVICE

CONNECTION DEVICE



Symbols

A symbol drawn on the screen is a graphical representation of a [Device](#). A symbol has the following properties.

Device Class - indicates the classification of the device represented.

Connection - Whether the symbol is connected to the circuit on its head or head-tail. The connection is basically determined by the device class, for example, head-tail for cables and transformers and head only for motors, generators and loads.

Label - A symbol has a label that is shown below and to the right of the symbol on the circuit display. This is also shown on the Status Bar. When first inserted in the circuit, the label is only a pre-set prefix (such as "T" for a transformer). When you start the calculation process, PowerNet automatically numbers the symbols if the device auto-number option flag is checked. The numbering sequence is left to right, top to bottom. For example, the top leftmost transformer label will now be "T1". The device label can be positioned by clicking on the label and dragging it to the desired position .

Position and Orientation - The symbol head is positioned on a snap grid point. It can be rotated around this point using the rotate buttons   or inverted using the invert button .

Grids and Lines

Grids - All connecting lines and device symbols are drawn between snap grids. The position of these grids may be shown or hidden by toggling the Snap Grid Button .

Lines - Connecting lines are drawn by dragging the mouse cursor across the screen while pressing the mouse left button. The line must be started by clicking the left mouse button on a snap grid position.

Copyright © 2010-2012 Megasys Software

Abbreviations

I - Current, amps

I_{pri} - Current, Primary Winding

I_{sec} - Current, Secondary Winding

I₁ - Current at device head

I₂ - Current at device tail

I_a, I_b, I_c - Line current

I_{fa}, I_{fb}, I_{fc} - Fault current

I_{rated} - Rated Current

I_{st}/I_{fl} - Starting to Full Load Current Ratio

kA - Current, amps X 1000

kAsc - Short Circuit Current X 1000 amps

kW - kilowatt

kVA - kilo-voltamps

kVAr - kilo-voltamps reactive

MVAsc - Short Circuit MVA

R - resistance, ohms

R/km - unit resistance per km

R/kft - unit resistance per 1000 ft

V₁ - voltage at device head

V₂ - voltage at device tail

V_d - voltage drop, volts

V_{pri} - voltage, primary winding

V_{sec} - voltage, secondary winding

V_{an}, V_{bn}, V_{cn} - Line to neutral voltage

V_{ab}, V_{bc}, V_{ca} - Line to line voltage

% Load - loading in percent

% R - Percent resistance referred to device base impedance

% Tap - percent tap referred to the winding where the tap is located.

% VR - Voltage regulation in percent

% X - percent reactance referred to device base impedance

% X₀ - percent zero sequence reactance referred to device base impedance

% X₂ - percent negative sequence reactance referred to device base impedance

% X' - percent transient reactance referred to device base impedance

% X'' - percent sub-transient reactance referred to device base impedance

% X_s - percent synchronous reactance referred to device base impedance

X - Reactance, ohms

X/km - unit reactance, ohms per kilometre



X/kft - unit reactance, ohms per kilofeet

P.F. - power factor

Sets - number of conductor sets in parallel

Using the symbols toolbar



Use the symbols button  to show or hide the symbols toolbar. The next symbols group button  and previous symbol group button  selects the symbol group to display on the symbols toolbar.

Hover the mouse over any of the symbols on the toolbar to display the device class or type on the status bar.

Select a symbol by clicking on a symbol button, then move the mouse to the desired grid location on the screen. Note that the cursor shape changes to indicate the symbol orientation depending on the position of the cursor relative to the snap grid point. Left click the mouse button to add the symbol to the circuit diagram.



A symbol must be selected to enable editing the symbol set using the [symbol set toolbar](#).

Manipulating the symbols

To move a symbol on the screen simply click on the symbol and drag it to the new position while holding the left mouse button. Release the button to position the symbol on the closest snap grid point.

To move a group of symbols, connecting lines and graphics objects, select the group. Left click and hold the mouse button on the upper left corner of the desired area. Drag the cursor to the opposite corner until the desired block size is shown. Releasing the mouse button will select all the symbols, connecting lines and graphics inside the selection area. Group of symbols may also be selected by holding the [SHIFT] button and selecting each symbol in turn.

Next, left click on any selected object and drag the mouse cursor across the screen until the symbols are positioned over the desired area. Release the mouse button.

Each symbol can be individually rotated around its head point using the clockwise button  or the counter-clockwise button . It can also be inverted head to tail using the invert button .

Copyright © 2010-2012 Megasys Software

Drawing connecting lines

Connecting lines are used to connect device symbols to form a circuit. If the circuit is active, selecting a line by clicking on it will display the electrical data for that line on the meter bar. Hover the mouse over a connecting line to show a data tip window as shown below.

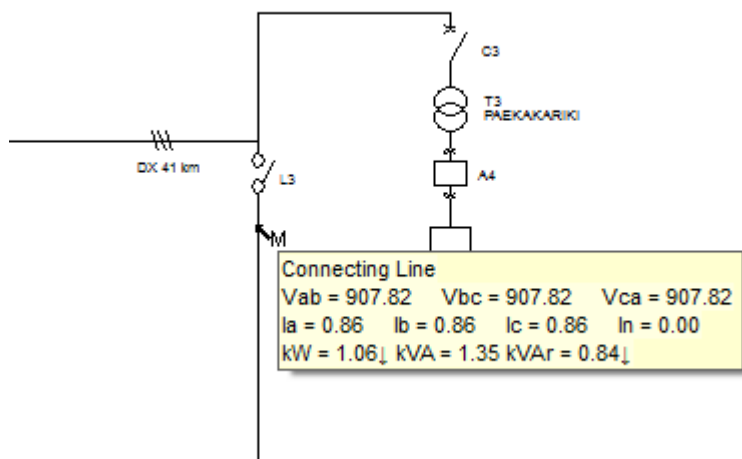

To draw connecting lines, position the mouse cursor over a snap grid point. The mouse cursor will turn to cross-hair when positioned properly over a snap grid point. To show the grid points, click on the snap grid button  on the [Circuit Toolbar](#).

Press and hold the left mouse button and drag the cursor across the screen. A rubber banding line will show where the line will be drawn. Release the mouse button when the desired direction and length of the line are shown.

When adding new connecting lines, the lines will automatically cross over intersected lines without connecting to those lines.

Copying and pasting symbols and blocks of symbols

To duplicate a device symbol, hold the [Ctrl] key, left click the center of the symbol and drag the cursor to the desired position before releasing the mouse button.

To duplicate a group of symbols, the symbols must first be selected. To do this, click and hold the mouse button on the upper left corner of the desired area. Drag the cursor to the opposite corner until the desired block size is shown. Releasing the mouse button will select all the symbols, connecting lines and graphics inside the selection area. Alternatively, select a group of symbols by holding the [SHIFT] key while clicking on the symbols to be selected.

Next, press and hold the [Ctrl] key, left click on any selected object and drag the mouse cursor across the screen until the symbols are positioned over the desired area. Release the mouse button.

Note that when copying or duplicating symbols or group of symbols, the device attributes, including the device data are copied over to the new symbols.

To copy the selected symbols, lines and graphics objects to Windows clipboard, click on the Copy Button on the main toolbar. or choose Edit|Copy from the menu bar.

Symbols previously saved to Windows clipboard may be pasted in any vacant area on the screen. To start paste operation, click on the Paste Button. The cursor changes to a paste cursor. Position the cursor over the insertion point (top left corner of the block to be pasted) and click the mouse left button.

Note that the symbol or symbols to be pasted must not overwrite any existing connecting line or symbol. Otherwise, the paste operation will fail.

Positioning Symbol Labels

To position a symbol label, click on the label and drag the cursor to the desired position before releasing the mouse button. Note that the label text may not be modified by double clicking. To edit the symbol label, open the symbol properties, select the General tab to edit the text and Options tab to select label, name or data to add to the device label.

Copyright © 2010-2012 Megasys Software

Graphics Elements

Graphics elements do not affect the circuit calculation but are useful for complementing the presentation of the circuit diagram.

Graphics elements can be used to:

- annotate the circuit diagram
- graphically modify individual symbols
- add captions
- create nameplates
- show borders
- delineate circuit sections

The following graphical elements are provided:





- line
- rectangle
- rounded rectangle
- ellipse
- elliptical arc
- elliptical pie
- elliptical chord
- polygon
- polyline
- text

Graphics Operations



Before creating or manipulating any graphics, click on the  toolbar button to hide the snap grids, unless you want the graphics to be sized and located on the snap grid points.

To create a graphics object, select the desired shape from the toolbar buttons, left click on the top left corner and drag the cursor to the bottom right to the approximate size. For polygons and polylines, double click the last vertex to complete the polyline/polygon.

Graphics objects, like symbols and connecting lines can be moved, deleted, duplicated and used with Windows clipboard operations. They can also be sized. To select a graphics object, click on the inside if it is solidly filled or on the outline if not. Selecting a graphics object creates grab handles for that object, which can be clicked and dragged to resize the graphics object.

All graphics objects will be layered such that the newer objects will display on top of older objects. A selected object can be moved towards the front or back by using the following toolbar buttons,    .

To select several objects, press and hold the [Shift] key and left click on individual objects. To select objects within an area, left click on the top left of the area and drag the rubber banding selection rectangle to the bottom right.

Several graphics object can be grouped together as single object. To do this, select the objects as above, then click the  toolbar button. To ungroup the objects, click the  button.

Graphics Properties

Double clicking a graphics object will display one of the following properties box.

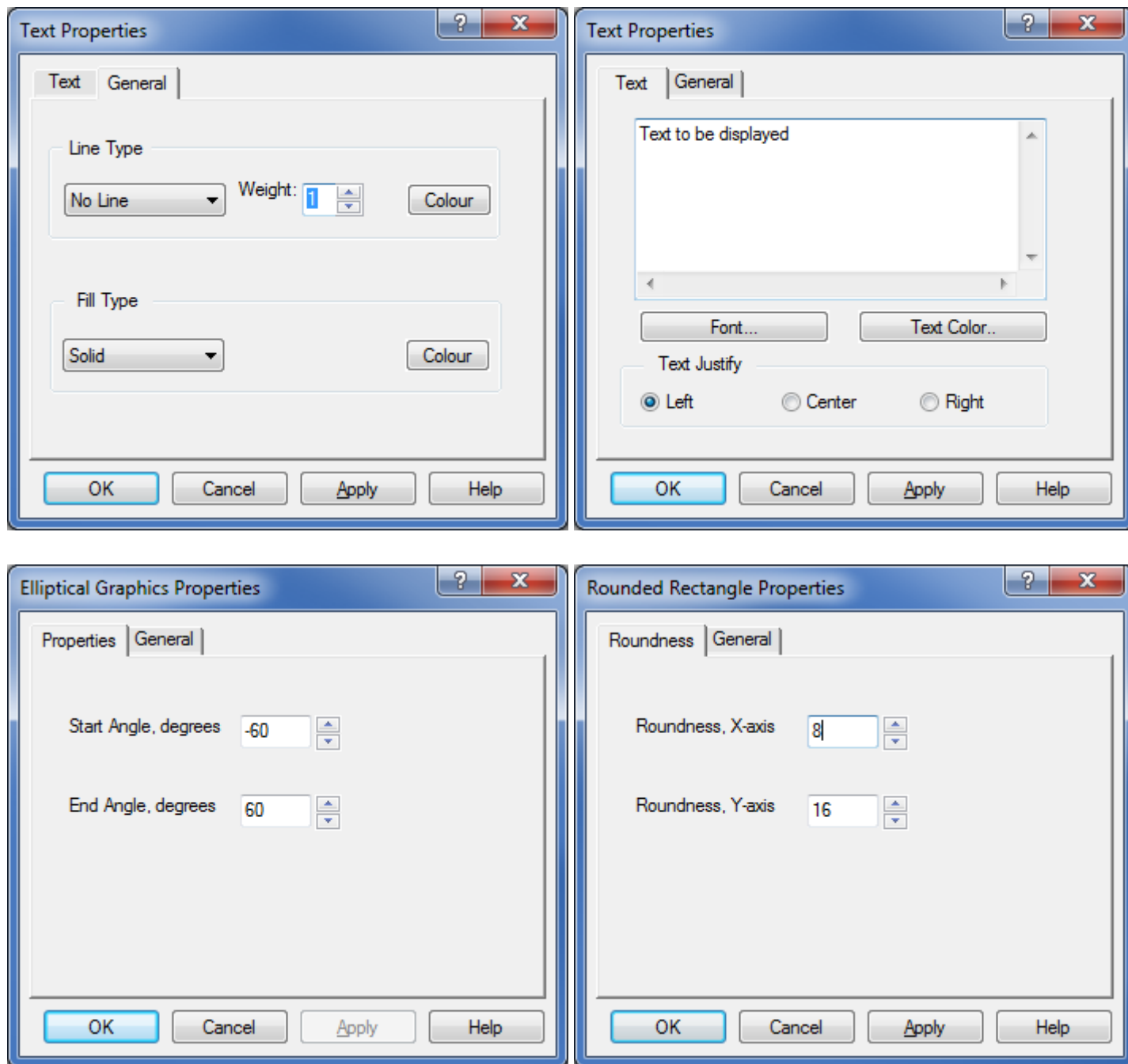

The outline can be invisible, solid, dotted, dashed or dot-dash. The fill can be invisible, solid, or hatched. The outline and fill can have the same or different colors. Click the colour button to display the [colour selection dialog box](#).

For text graphics, click on the [Font] button to display the [font selection](#) box.

For elliptical graphics, zero degrees is +x axis (3:00 o'clock), positive is counter-clockwise. The graphics starts at the start angle and moves counter-clockwise towards the end angle.

For rounded corner rectangles, the X and Y axis roundness refers to the relevant radii of the ellipse quadrant used to form the rounded corners of the rectangle.

Device General Info

Double click on a symbol or select Device Properties from the menu. Select the general tab to display the following dialog box.

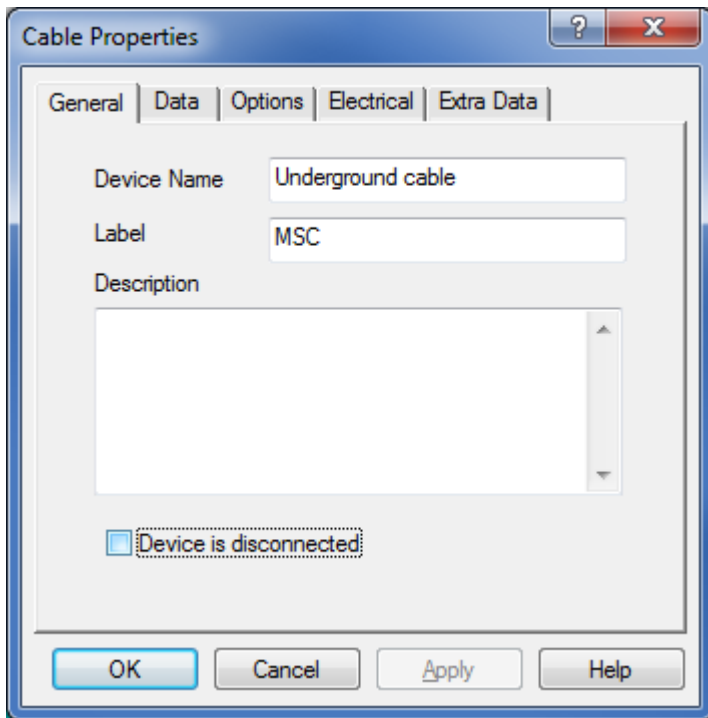

Device Name - Optional. If not blank, this will be used instead of the generic device class name for the circuit report. Can be displayed next to symbol.

Label - Optional. Can be displayed next to symbol.

Description - Optional. Included in circuit report.

Device is disconnected - When checked, this device is not included in circuit calculation (open circuited).

Device Options

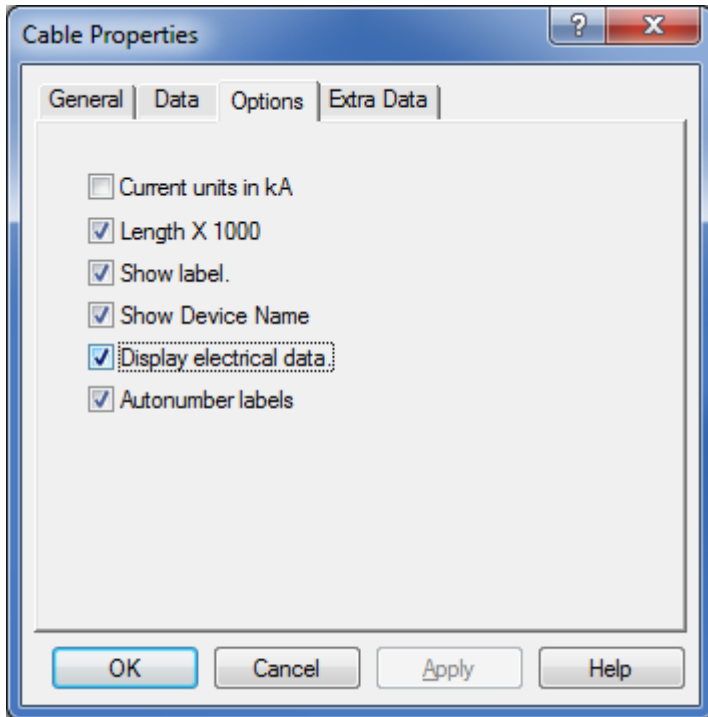

Each device class has its own set of option flags. Furthermore, each individual device in the circuit can have its flags set separately. For example, you can check the auto-number for one to renumber it every time the circuit is modified and recalculated, while another may be unchecked so that its label remains constant.

Device Database

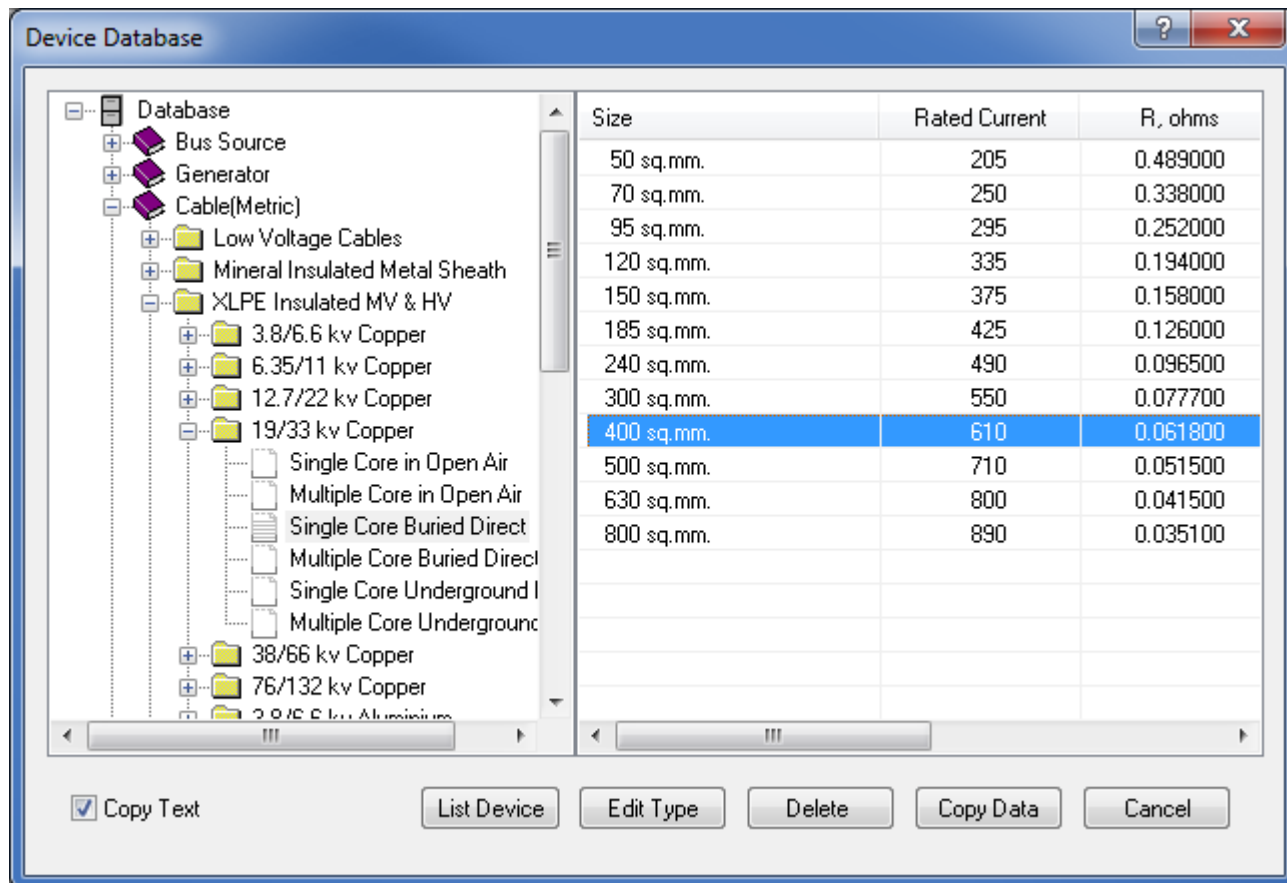

The device database can be used to fill in the device data entry form with typical values. Click [Copy Data] button to fill the form with values from the database.

Copy Text - Check this to copy the data record type into the device description field.

List Device- Create a new device record using the device data values. Record type will be "New Data Record".

Edit Type- Edit the data record Type/Size field.

Delete - Delete the selected data record. This action can not be undone.

Copy Data- Use the record values to fill in the device data.

Bus Device Data

The image shows a software dialog box titled "Bus Properties" with a "Data" tab selected. The dialog contains several input fields and buttons. The fields are: "Voltage in volts" with a value of 3300, "Short circuit kVA" with a value of 15000, "R/X Ratio" with a value of 0.1, "Torque Angle, degrees" with a value of 1.5, and "Zero Sequence X, %" with a value of 10. There is also a dropdown menu for "Earthed Neutral". At the bottom of the dialog, there are buttons for "Auto Fill", "Database", "OK", "Cancel", "Apply", and "Help".

Voltage in kV - the no load voltage of this bus source.

Short circuit MVA - the estimated or calculated short circuit capacity of this bus.

R/X Ratio - the internal impedances resistance to reactance ratio.

Torque Angle, degrees - Angle between internal voltage and terminal voltage. Use to adjust kilowatt loading. Typical values of between 1 and 5 degrees.

Earthed Neutral - Bus neutral is earthed. Required for fault calculations.

Zero Sequence X, % - Zero sequence reactance as percentage of base impedance. Required for fault calculations.

Auto Fill - automatically fill this form using previous values.

Database - opens the device database of sample bus sources.

Cable Device Data

The image shows a software dialog box titled "Cable Properties" with a "Data" tab selected. The dialog contains several input fields and buttons. The fields are: "Conductor impedance" with sub-fields "R, ohms/1000 meters" (value 0.108) and "X, ohms/1000 meter" (value 0.3113); "Length in km." (value 38.4); "Sets in parallel" (value 1, with up/down arrows); "Rated current in amps." (value 460); and "Temp rise, degrees C" (value 0). At the bottom of the dialog are buttons for "Auto Fill", "Metric", "Database", "OK", "Cancel", "Apply", and "Help".

Property	Value
Conductor impedance R, ohms/1000 meters	0.108
Conductor impedance X, ohms/1000 meter	0.3113
Length in km.	38.4
Sets in parallel	1
Rated current in amps.	460
Temp rise, degrees C	0

R, ohms/1000 meters - the cable resistance per 1000 meters for each phase. Note that this value is temperature dependent.

X, ohms/1000 meters - the cable reactance per 1000 meters for each phase. The neutral impedance is assumed to be zero.

Length in meters - the cable length.

Rated current in amps - the rated ampacity of the cable. Note that this dependent on temperature and installation configuration.

Temp rise, degrees C - the actual cable temperature above the datum, normally 25 degrees C. Affects cable resistance.

Sets in parallel - number of cable sets in parallel. Cable sizes and installation configuration must be identical.

Auto Fill - automatically fill this form using previous values.

Metric/Imperial - switch between metric and imperial versions of device database.

Database - opens the device database of sample cable types.

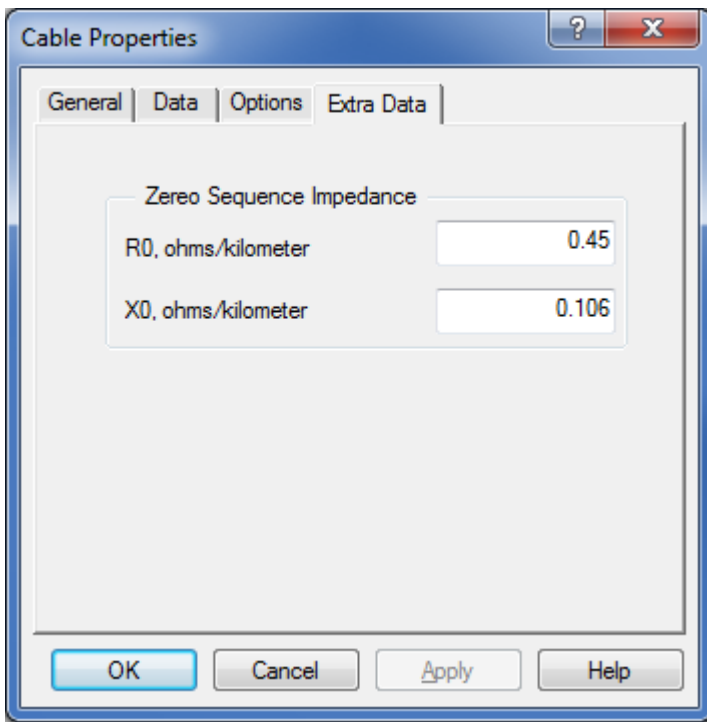

R_0 , ohms/1000 meters - zero sequence resistance per unit length.

X_0 , ohms/1000 meters - zero sequence reactance per unit length.

The zero sequence impedance is used in fault calculations. The impedance of the neutral conductor should not be included

in this impedance as the neutral is assumed to be earthed at the source and at the fault. If the fault is between a line and the

neutral conductor, this may be simulated by using the neutral impedance as the source earthing impedance.

Capacitor Device Data

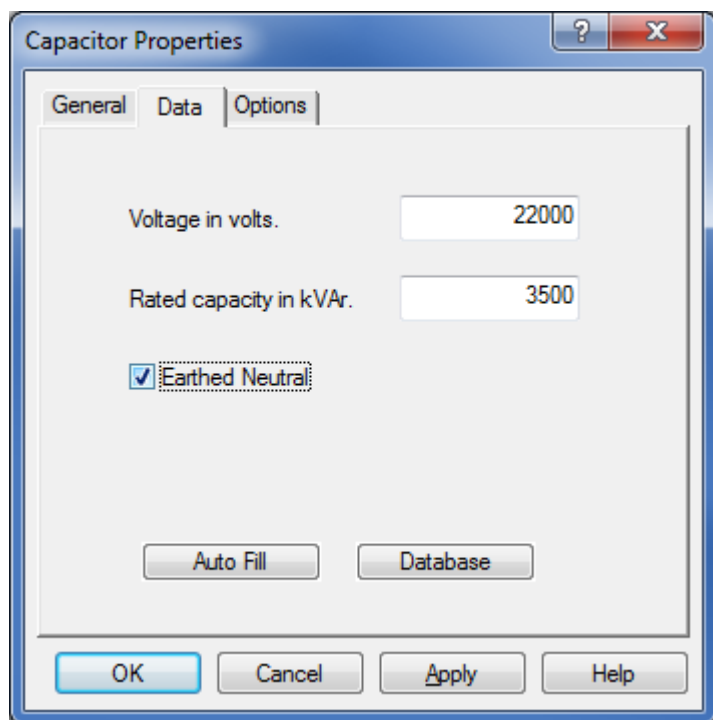

The image shows a software dialog box titled "Capacitor Properties" with three tabs: "General", "Data", and "Options". The "Data" tab is selected. It contains two text input fields: "Voltage in volts." with the value "22000" and "Rated capacity in kVAr." with the value "3500". Below these is a checked checkbox labeled "Earthed Neutral". At the bottom of the dialog are four buttons: "Auto Fill", "Database", "OK", "Cancel", "Apply", and "Help".

Voltage in volts - Operating voltage of the capacitor bank/assembly.

Rated capacity in kVAr - rated kilovar capacity of the capacitor bank/assembly.

Earthed Neutral - check this button if the capacitor neutral is connected to earth.

Auto Fill - automatically fill this form using previous values.

Database - opens the device database of sample capacitors.

Generator Device Data

The screenshot shows a software dialog box titled "Generator Properties" with a "Data" tab selected. The dialog contains several input fields and buttons. The fields are: "Rated Capacity in MVA" (12.5), "Voltage in kV" (11.2), "Voltage Regulation, %" (1.5), "R/X Ratio" (0.1), and "Torque Angle, degrees" (1.6). Below these is a section for "Earthed Neutral" with a checked button, and two more fields: "Earth resistance, ohms" (0) and "Earth reactance, ohms" (0). At the bottom of the dialog are buttons for "Auto Fill", "Database", "OK", "Cancel", "Apply", and "Help".

Rated capacity in MVA - rated capacity of the generator.

Voltage in volts - No-load voltage of the generator.

Voltage Regulation % - the difference between no load and full load voltage divided by full load voltage in percent.

R/X Ratio - Resistance to reactance ratio of the generator internal impedance.

Torque Angle, degrees - Angle between internal generated voltage and terminal voltage. Use to adjust kilowatt loading. Typical values of between 1 and 5 degrees.

Earthed Neutral - check this button if generator neutral is connected to earth.

Earth resistance, ohms - value of resistance between neutral and earth.

Earth reactance, ohms - value of resistance between neutral and earth.

Auto Fill - automatically fill this form using previous values.

Database - opens the device database of sample capacitors.

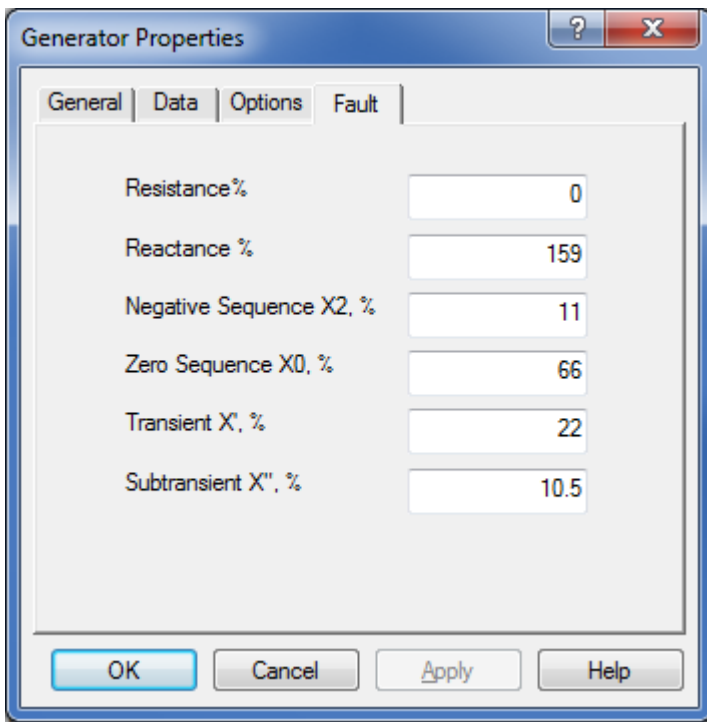

Resistance % - machine resistance in percent base.

Reactance % - machine reactance in percent base.

Negative Sequence X2, % - negative sequence reactance in percent base.

ZeroSequence X0, % - zero sequence reactance in percent base.

Transient X', % - transient reactance in percent base.

Subtransient X'', % - subtransient reactance in percent base.

Load Device Data

The screenshot shows a software dialog box titled "Load Properties". It has three tabs: "General", "Load", and "Options", with "Load" currently selected. The dialog contains three input fields with the following values: "Voltage in volts" is 480, "Rated Capacity in kVA" is 25, and "Load Power Factor" is 0.85. Below these fields is a button labeled "Earthed Neutral". At the bottom of the dialog, there are four buttons: "Auto Fill", "Database", "OK", and "Cancel".

Voltage in volts - Operating voltage of the load.

Power in kVA - Specify the operating kVA of this load.

Load P.F. - Enter the load operating power factor.

Earthed Neutral - Click to toggle neutral to earth connection.

Auto Fill - automatically fill this form using previous values.

Database - opens the device database of sample loads.

Induction/Synchronous Motor Device Data

The screenshot shows a software dialog box titled "Induction Motor Properties". It has three tabs: "General", "Data", and "Options", with "Data" currently selected. The dialog contains several input fields with numerical values: "Voltage in volts" (3300), "Motor power in kW" (500), "Motor P.F." (0.85), "Efficiency %" (88), "Subtransient X'', %" (0), "Loading %" (120), and "Start-Full Load Ratio" (5). Below these fields are four buttons: "Running" (highlighted in blue), "Starting", "Auto Fill" (dotted border), and "Database". At the bottom of the dialog are four standard buttons: "OK", "Cancel", "Apply", and "Help".

Voltage in volts - Operating voltage of the motor.

Power in kW - Specify the rated power output of this motor.

Motor P.F. - Enter the actual motor operating power factor.

Efficiency, % - the mechanical efficiency of the motor. About 80% at 3.75kW(5HP) and 90% at 37.5(50HP).

Subtransient X'', % - subtransient reactance in % of base impedance. Required for fault calculations. Typically, 20-25%.

Loading % - Specify the percent loading for the motor. Normally 100 or less, more for simulating overload.

Start-Full Load Ratio - the ratio of starting current to the full loads current. Between 1.5-15, typically 6.5.

Running/Starting - Select to determine motor current.

Auto Fill - automatically fill this form using previous values.

Database - opens the device database of sample motors.

Synchronous Motor

Synchronous Motor Properties

General | Data | Fault | Options

Voltage in volts. 3300

Motor power in kW. 1500

Power Factor **Lagging** 0.92

Efficiency % 92

Loading % 50

Earthed Neutral

Re 0 Xe 0

Auto Fill Database

OK Cancel Apply Help

Voltage in volts - Operating voltage of the motor.

Motor Power in kW - Specify the rated power output of this motor.

Motor P.F. - Enter the actual motor operating power factor.

Efficiency, % - the mechanical efficiency of the motor.

Earthed Neutral - check this button if motor neutral is connected to earth.

Earth resistance, ohms - value of resistance between neutral and earth.

Earth reactance, ohms - value of reactance between neutral and earth.

Auto Fill - automatically fill this form using previous values.

Database - opens the device database of sample motors.

Synchronous Motor Properties

General | Data | Fault | Options

Resistance% 0.6

Reactance % 120.0

Negative Sequence X2, % 40.0

Zero Sequence X0, % 21.0

Transient X', % 95.0

Subtransient X'', % 40.0

OK Cancel Apply Help

Resistance % - machine resistance in percent base.

Reactance % - machine reactance in percent base.

Negative Sequence X2, % - negative sequence reactance in percent base.

ZeroSequence X0, % - zero sequence reactance in percent base.

Transient X', % - transient reactance in percent base.

Subtransient X'', % - subtransient reactance in percent base.

Copyright © 2010-2012 Megasys Software

Protective Device Data

The screenshot shows a software dialog box titled "Protective Device Properties". It has three tabs: "General", "Protective Device", and "Options". The "Protective Device" tab is selected. The dialog contains several input fields and buttons:

- Type:** A dropdown menu set to "Oil Circuit Breaker".
- Voltage in volts:** A text input field containing "22000".
- Trip setting, amps:** A text input field containing "100".
- Interrupting Rating, kA:** A text input field containing "500".
- Momentary Rating, kA:** A text input field containing "2000".
- Frame Size, amps:** A text input field containing "1200".
- Buttons:** "Auto Fill" and "Database" are located below the input fields. "OK", "Cancel", "Apply", and "Help" are located at the bottom of the dialog.

Note that all data are optional and not used during calculation. The trip current will indicate if exceeded in the calculation.

Type - Select fuse, air circuit breaker or oil circuit breaker.

Voltage in kV - rated voltage of the device.

Trip Current, amps - the current setting of the trip element of the device.

Interrupting Rating, kA - the maximum current the device can safely break.

Momentary Rating, kA - the maximum current the device can safely withstand.

Frame Size - For molded case and similar protective devices..

Auto Fill - automatically fill this form using previous values.

Database - opens the device database of sample protective devices.

Transformer Device Data

The screenshot shows the 'Transformer Properties' dialog box with the 'General' tab selected. The 'Pri/Sec' dropdown is set to 'Delta-Delta'. The 'Rated Capacity in kVA' is 1500, 'Primary voltage, volts' is 22000, and 'Secondary voltage, volts' is 480. The 'Tap %' is 2.5. 'Percent R' is 1.5 and 'Percent X' is 6.6. There are 'Auto Fill' and 'Database' buttons at the bottom of the main area, and 'OK', 'Cancel', 'Apply', and 'Help' buttons at the very bottom.

Field	Value
Pri/Sec	Delta-Delta
Rated Capacity in kVA	1500
Primary voltage, volts	22000
Secondary voltage, volts	480
Tap %	2.5
Percent R	1.5
Percent X	6.6

- Pri/Sec* - Select primary and secondary winding type.
- Rated Capacity in kVA* - Enter transformer capacity in kVA.
- Primary voltage, volts* - Operating voltage, primary.
- Primary/Secondary* - Selects which winding is tapped.
- Tap %* - Percentage tap on the winding.
- Secondary voltage, volts* - Operating voltage, secondary.
- Percent R* - Percent of base impedance, resistance.
- Percent X* - Percent of base impedance, reactance.
- Auto Fill* - automatically fill this form using previous values.
- Database* - opens the device database of sample transformers.

The screenshot shows the 'Transformer Properties' dialog box with the 'Data' tab selected. The 'Winding Configuration' is 'Delta-Wye'. 'Zero Sequence X, %' is 4.5. The 'Primary Neutral Earthed' button is selected. Below it, 'R, ohms' and 'X, ohms' are both 0. The 'Secondary Neutral Earthed' button is also selected, with 'R, ohms' and 'X, ohms' both 0. 'OK', 'Cancel', 'Apply', and 'Help' buttons are at the bottom.

Field	Value
Winding Configuration	Delta-Wye
Zero Sequence X, %	4.5
Primary Neutral Earthed	Selected
Primary R, ohms	0
Primary X, ohms	0
Secondary Neutral Earthed	Selected
Secondary R, ohms	0
Secondary X, ohms	0

Zero Sequence X, % - Zero sequence reactance of transformer windings.

Primary Earthed - Neutral connection of primary winding is earthed.

Secondary Earthed - Neutral connection of secondary winding is earthed.

R, ohms - Earthing resistance between neutral and earth.

X, ohms - Earthing reactance between neutral and earth.

Copyright © 2010-2012 Megasys Software

Transmission Line

The screenshot shows a software dialog box titled "Transmission Line Properties". It has three tabs: "General", "Data", and "Options". The "General" tab is selected. Inside the dialog, there are seven input fields with their corresponding values:

Parameter	Value
R, ohms/1000 meters	0.27
X, ohms/1000 meter	1.05
C, nanoFarad/kilometre	12.6
R0, ohms/kilometer	0.37
X0, ohms/kilometer	1.45
C0, nanoFarad/kilometre	9.15
Length in km.	285

At the bottom of the dialog, there are four buttons: "Auto Fill", "Database", "OK", "Cancel", "Apply", and "Help".

R, ohms/1000 meters - the line resistance per 1000 meters for each phase. Note that this value is temperature dependent.

X, ohms/1000 meters - the line reactance per 1000 meters for each phase. The neutral impedance is assumed to be zero.

C, nanofarads/1000 meters - mutual capacitance.

C0, nanofarads/1000 meters-capacitance to earth.

Length in km- the line length.

Auto Fill - automatically fill this form using previous values.

Database - opens the device database of sample cable types.

Impedance Device Data

The image displays two instances of the 'Impedance Properties' dialog box, illustrating the transition between impedance and admittance modes.

Left Window (Impedance Mode):

- General tab selected.
- Resistance, ohms: 0.305
- Reactance, ohms: 0
- Buttons: Impedance (selected), Admittance
- Buttons: Auto Fill, Database
- Buttons: OK, Cancel, Apply, Help

Right Window (Admittance Mode):

- General tab selected.
- Conductance, mho: 0.305
- Susceptance, siemens: 0.42
- Buttons: Impedance, Admittance (selected)
- Buttons: Auto Fill, Database
- Buttons: OK, Cancel, Apply, Help

Resistance, ohms - the actual device resistance in ohms.

Reactance, ohms - the actual device reactance in ohms.

Impedance - select conductance/susceptance data entry.

Admittance - select resistance/reactance data entry.

Auto Fill - automatically fill this form using previous values.

Database - opens the device database of sample impedances.

Calculation

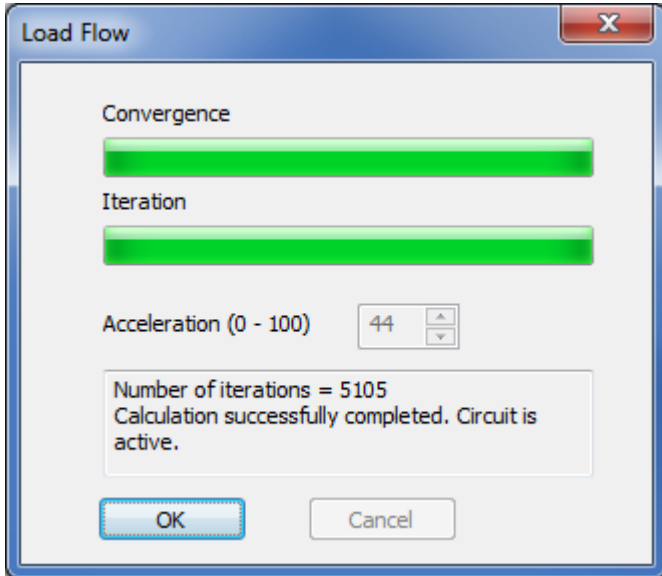

Overview

After drawing the circuit and entering data for each device, click on the calculate button . The circuit is analyzed for correctness and completeness of data for all devices. If there are no errors, the circuit is calculated. After calculation, all electrical information on each device and connecting lines can be displayed. The circuit is then said to be active.

Math

The circuit is simulated as an admittance matrix. The matrix is solved by iteration using accelerated Gauss-Siedl method. The speed of calculation convergence can be influenced to a limited extent by adjusting the acceleration factor. The number of iterations can also be adjusted to cater for slowly converging circuits.

Fault

For faults, the circuit is first calculated for load flow. All power sources are then short-circuited and the voltage at the fault point is used as the sole power source. The circuit is then configured and calculated as positive sequence, negative sequence and zero sequence. The sequence components are combined with the load flow to determine the voltages and current throughout the circuit during fault conditions.

Tips

Most real life circuits will calculate, converging rapidly. Failure to converge may be due to one of the following:

- *Resonance* - perfect or near perfect resonance can not be calculated. A non-negligible resistance between inductance and capacitance elements must be included.
- *Extremely small or extremely large inductances* - solving a large bus-bar with negligible impedance in series with a long transmission line may not converge. Simulate bus bar as connecting line instead.

See Also:

[Circuit Analysis](#)

Circuit Analysis

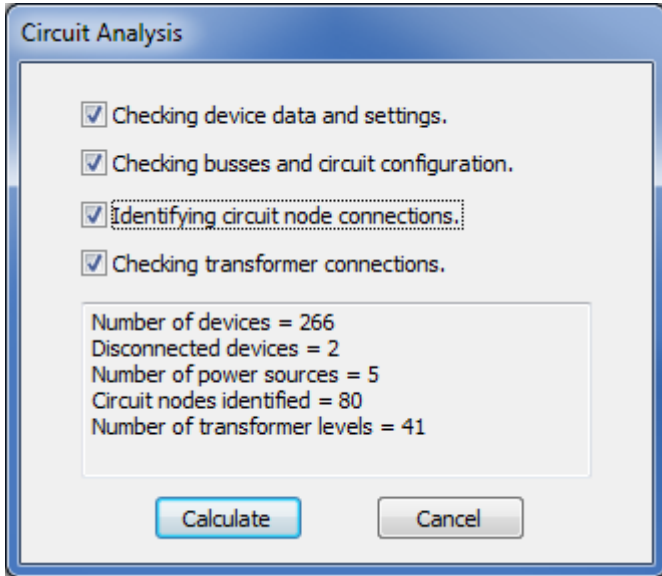

Analysis Procedure

- *Auto-number* - Devices are numbered in sequence unless flagged otherwise.
- *Check device data* - All devices are checked for correct and complete data. If no fault is simulated (load flow only), sequence impedance data are not required.
- *Check configuration* - the circuit must connect all devices and checks that there are no isolated devices or groups.
- *Check source bus* - At least one generator or source bus must be included.
- *Identify nodes* - Each node (junction) in the circuit is identified and numbered in preparation for calculation.
- *Identify transformer groups* - This procedure makes sure that there are no connecting path between primary and secondary windings for all transformers and parallel transformers have the same voltage ration and phase.

See also:

[Calculation](#)

Load Flow

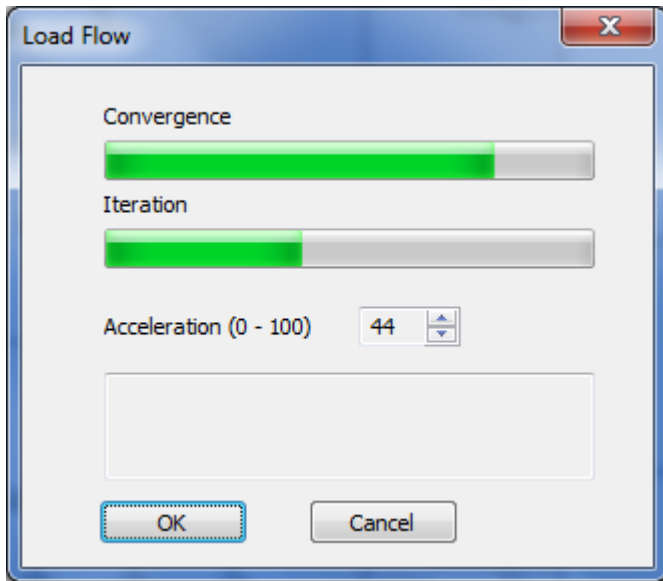

Convergence - shows progress of calculation converging to a solution.

Iteration- Number of iteration done. Iteration limit can be set in the circuit miscellaneous [settings](#).

Acceleration- Speed up solution convergence. Start with a value of 25 and increase or decrease if it takes too long for the solution to converge.

Message Box - Displays error or successful result of calculation.

Fault Simulation

Click on the fault simulation button  to position a fault on the circuit. The cursor changes to a fault cursor. Click on any grid point on the circuit diagram to position the fault. The fault properties dialog box comes up.

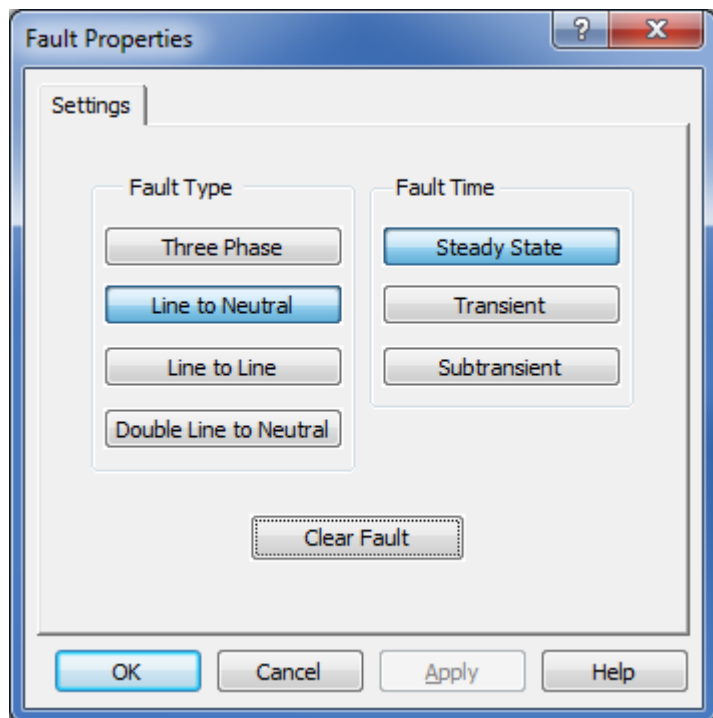

Select the type and time of fault calculation required and click OK. If there is an existing fault, click the clear fault button, then OK to remove the fault.

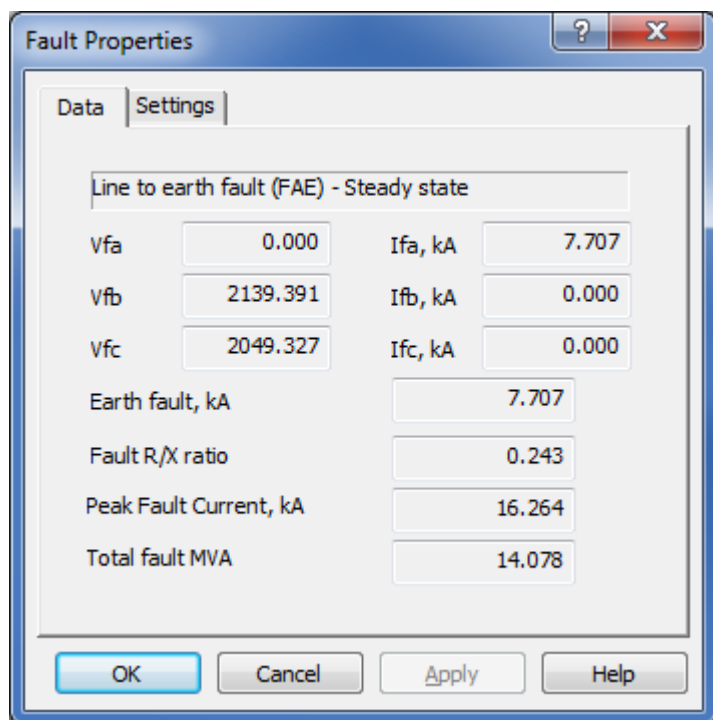

After circuit calculation fault data as shown above is displayed. This data is also included in circuit reports, right after the report header.

The following abbreviations are used for fault types:

FAE - line A to earth fault.

FBC - line to line fault between phase B and C

FBCN - line to line fault between phase B and C and earth
FABC - 3-phase bolted fault

Copyright © 2010-2012 Megasys Software

Electrical Data Display

If the circuit is active, double click a symbol or select Device/Properties from the menu to display electrical data as shown below. If the device is in a section of the circuit where the earthed neutral is available or the device has a neutral connection, neutral current and voltage to neutral data is included.

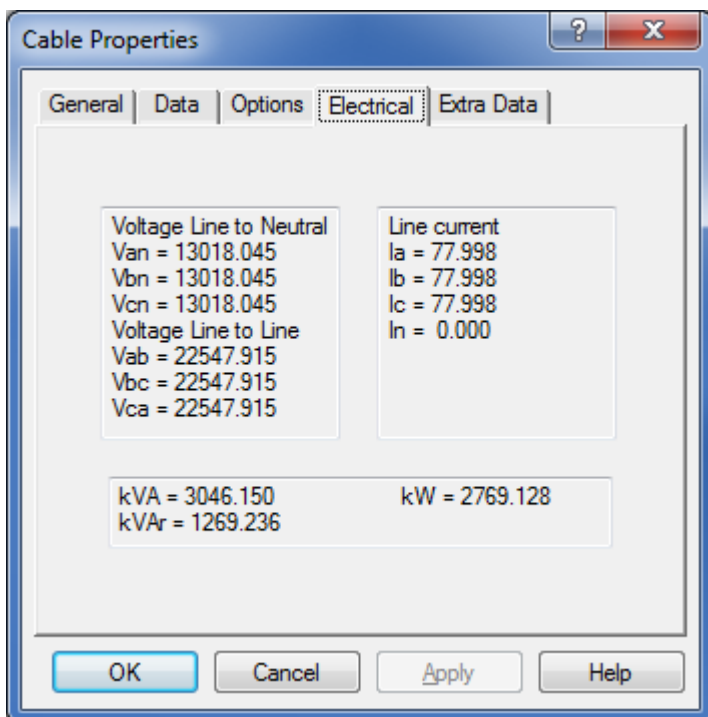
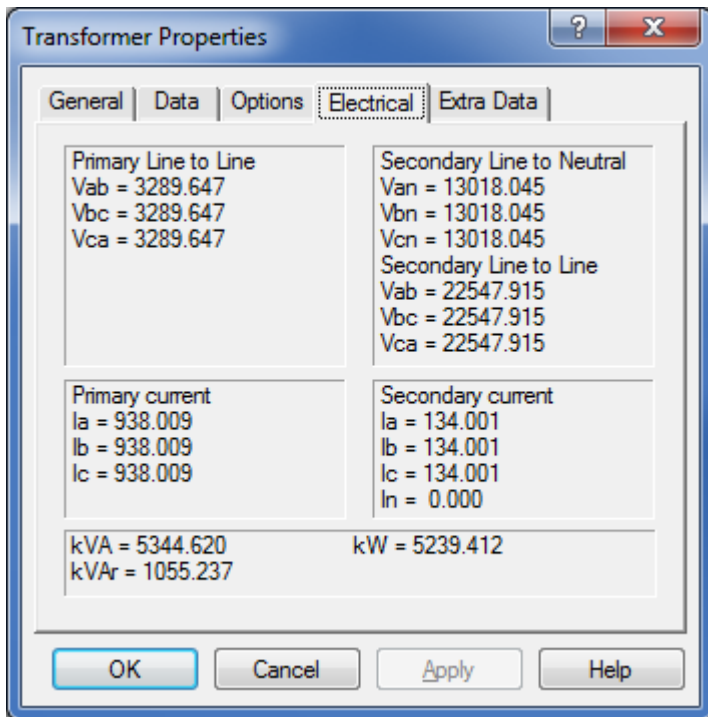

Data Tip Window

The data tip window is similar to the tool tip that appears when the mouse hovers over a toolbar button. Hover the mouse over any symbol or connecting line on an active circuit to display device information and electrical data, such as device label, name, voltages, current, kVA, kilowatt and kilovar flow.

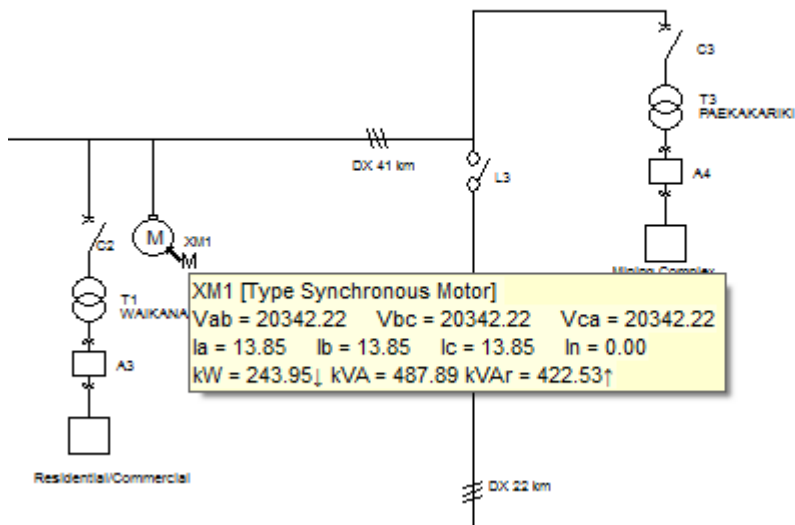

Device Meter Bar

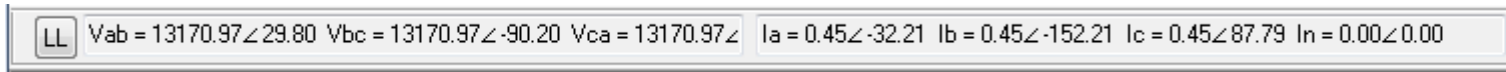



The meter bar is used to display electrical data for a device after the circuit is calculated. Select a device by clicking on it to display voltage, current and power. Voltages are measured at the head of the symbol. The current is through the device flowing from the head towards the tail. The kW and kilovar flows are indicated by arrows.

Click the button marked "LL" or "LN" to switch between line to line and line to neutral voltage indication. "LN" may not be selected if there is no neutral on that part of the circuit.

If no device is selected, the meter bar is blank.

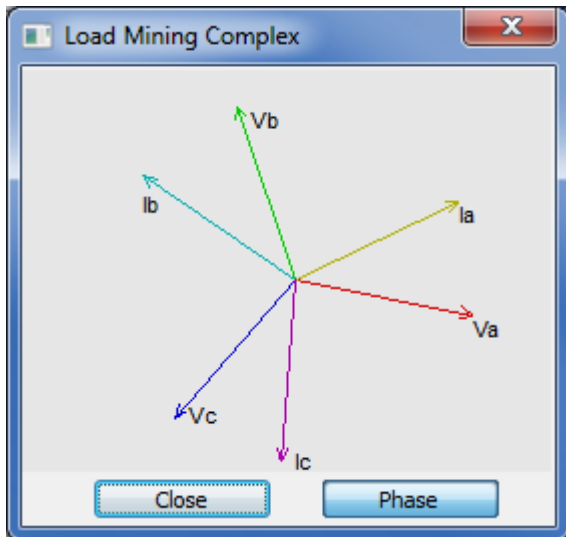
Vector Display



The vector display panel is available when the circuit has been calculated (active). Display this panel by clicking on the  button on the circuit toolbar.

Circuit option flags can be set to automatically display after each calculation.

Click on the [Phase] or [Line] button to toggle display between line to line and line to neutral voltage.

Circuit Report

Circuit Report

Project : Megasys Software Sample Project

Prepared by : John Smith

Circuit Fault Type -Line to earth fault (FAE) - Steady state

Fault on node connected to the following circuit elements:
 Transformer - TXF1
 Transformer - TXF2

Vfa = 0.00	Vfb = 2139.39	Vfc = 2049.33	
Ifa = 7707.19	Ifb = 0.00	Ifc = 0.00	Ifn = 7707.19

SB1 Bus

Voltage in volts.	11500	Van = 6225.19	Vbn = 6482.20	Vcn = 6505.15
Short circuit kVA.	552000	Vab = 10920.69	Vbc = 11397.97	Vca = 10958.63
Kilowatt out	2000	Ia = 2571.77	Ib = 397.15	Ic = 398.11
Neutral is earthed	Yes	kW = 7785.38↓	kVA = 20083.30	kVAr = 18512.88↓
Zero Sequence X0, %	0.5000			In = 2369.96

Gen1 Generator(disconnected)

Voltage in kV	11.20	Vab = 0.00	Vbc = 0.00	Vca = 0.00
Rated Capacity in MVA.	12.50	Ia = 0.00	Ib = 0.00	Ic = 0.00
Voltage Regulation, %	2.000	kW = 0.00↑	kVA = 0.00	kVAr = 0.00↑
Resistance%	0			In = 0.00
Reactance %	159.0			
Negative Sequence X2, %	11.00			
Zero Sequence X0, %	66.00			
Transient X', %	22.00			
Subtransient X'', %	10.50			
Neutral is earthed	No			

CB1 Protective Device

Voltage in volts.	3300	Van = 0.00	Vbn = 2139.39	Vcn = 2049.33
Trip setting, amps	250.0	Vab = 2139.39	Vbc = 3206.01	Vca = 2049.33
Interrupt rating, kA	0	Ia = 7707.19	Ib = 0.00	Ic = 0.00
Momentary Rating, kA	0	kW = 1627.00	kVA = 2027.05	kVAr = 1227.24
				In = 7707.19

Close Save As

A text report on the circuit can be displayed on screen. The report is in *rich text format (RTF)* which can be read in Microsoft WordPad, Word or most other word processing software for further formatting and editing.

For large circuits, PowerNet automatically opens WordPad if it is available to display the circuit report.

The electrical data format can be set in the calculation and data tab of the [default settings](#) properties page.

Units Settings

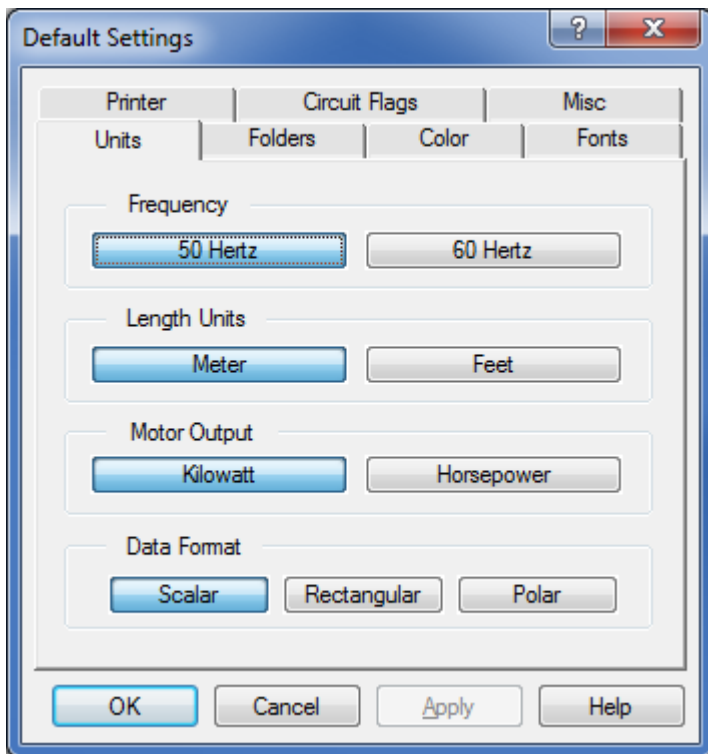

Frequency- default frequency used for all circuits. Frequency can be set for individual circuits. Used for transmission line calculations

Linear Units - default linear units for cables and transmission lines. Units can be set separately for each cable or transmission line.

Motor rating -default settings for all motors. Each motor rating can be set individually.

Data Format - Default format for voltage and current. Circuits formats can be set individually..

Folder Settings

The folders settings box is used to set the folder locations of the symbol set file as well as the database files.

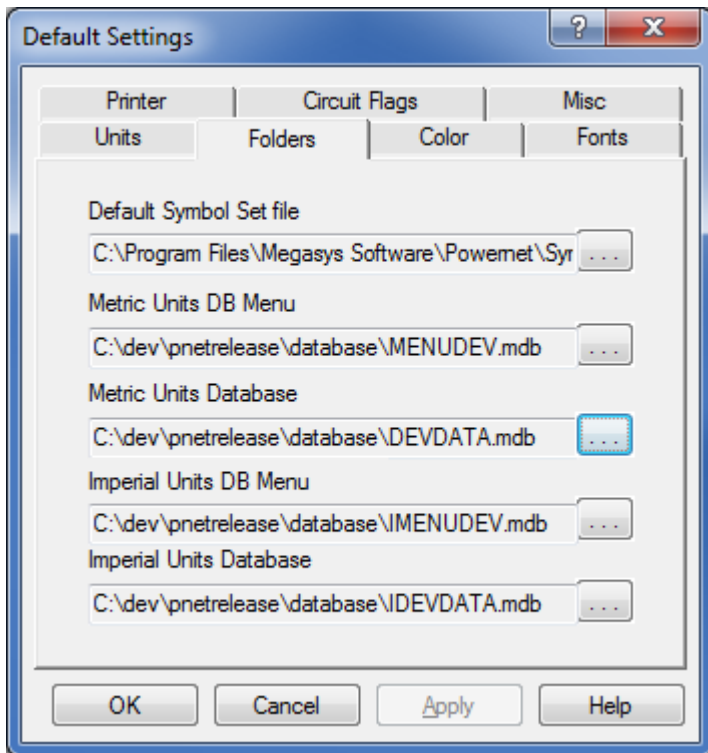

Click on the [. .] browse button to set to a different folder.

The default symbol set file is displayed when PowerNet starts up. To use another symbol set, select *Circuit/Symbol Set* from the main menu.

Colour Settings

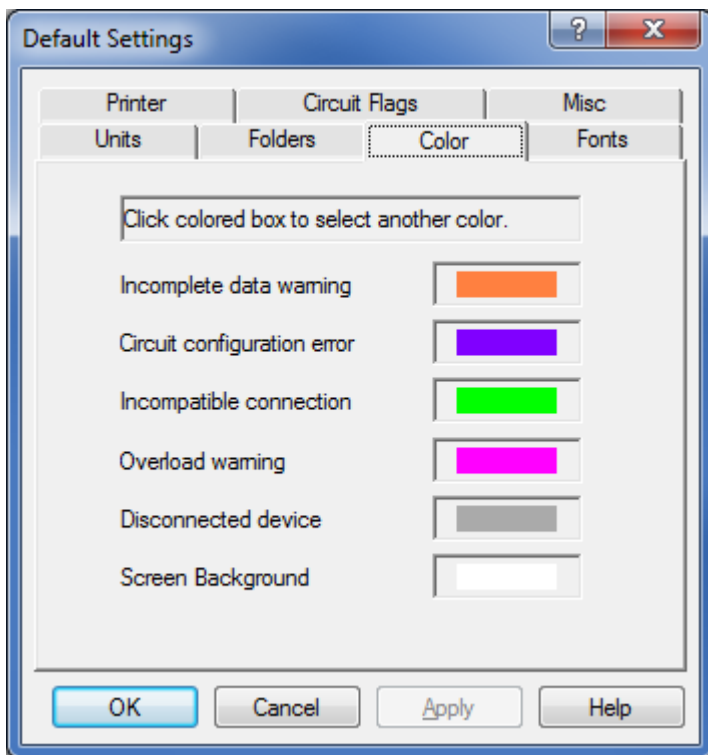

This properties page selects the color which will be used to highlight the device to which the applicable warning condition applies.

Copyright © 2010-2012 Megasys Software

Fonts Settings

The font settings box is used to select the default fonts.

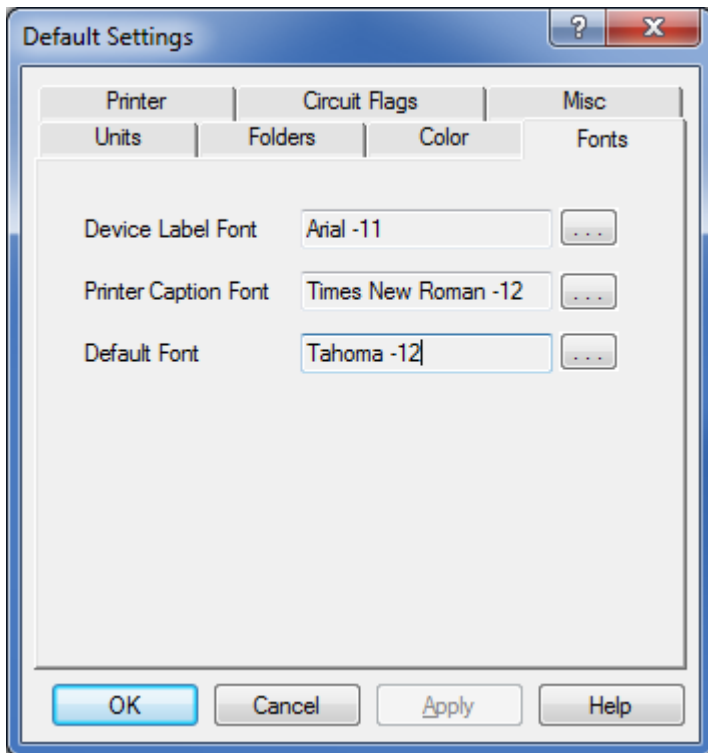

Device Label Font - All device labels for all circuits will be drawn with this label.

Printer Caption Font - The circuit project name at the bottom of the page will be printed with this font.

Default Font - Used for all text graphics. Individual graphics font can be set by editing the [graphics properties](#).

Printer Settings

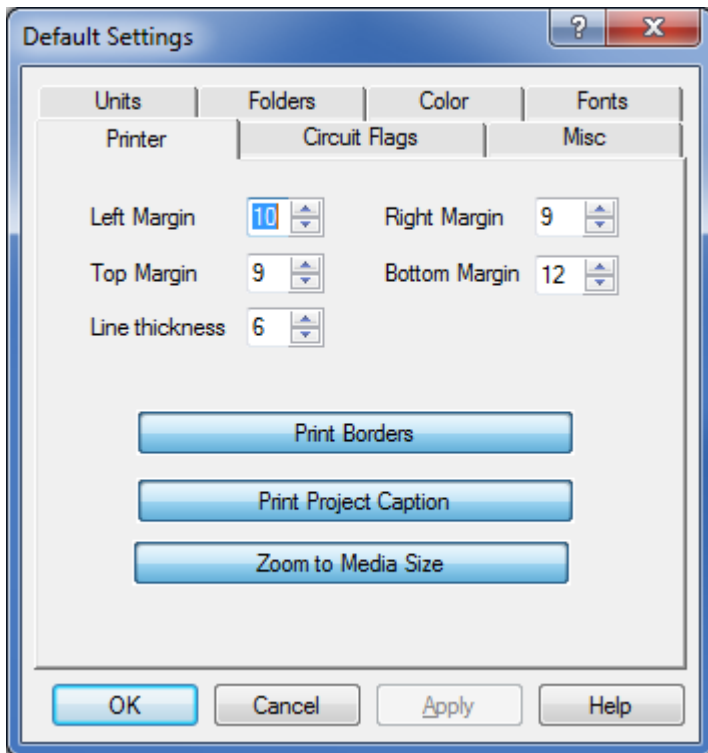

Margins - margins are in millimetre or inches.

Line thickness - adjust this to account for difference in line widths for different printers resolution.

Print Borders - Set this to draw a rectangular border inside the margins.

Print Project Caption - Set this to print the project file name, centered at the bottom of the page. The font is set using the [fonts](#) tab of this dialog box.

Zoom to Media Size - the circuit magnification is adjusted to fill the whole page.

Circuit Default Settings

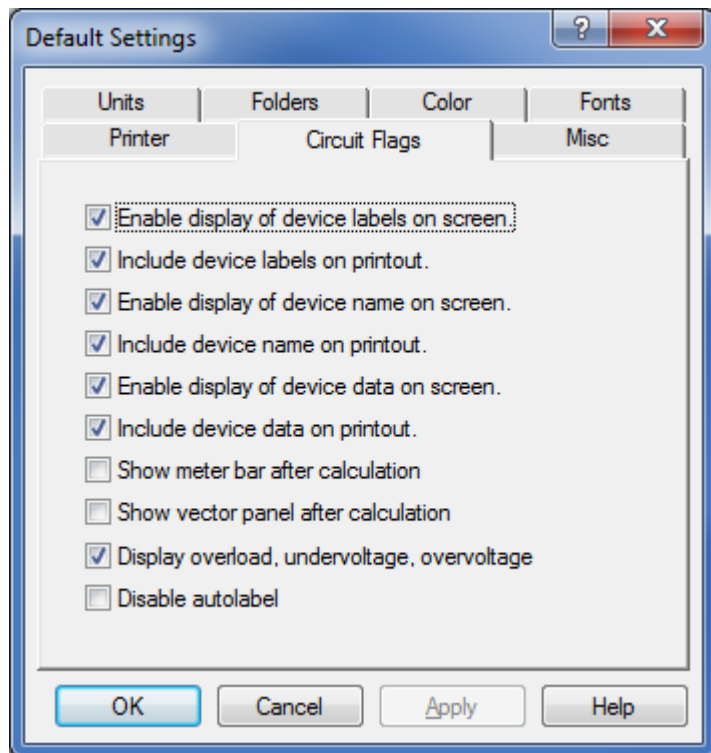

This dialog box is used for setting the default circuit option flags. Each new circuit starts with these settings. However, individual circuits can have their own settings by selecting [Circuits|Properties](#) from the main menu.

Calculation and Data Settings

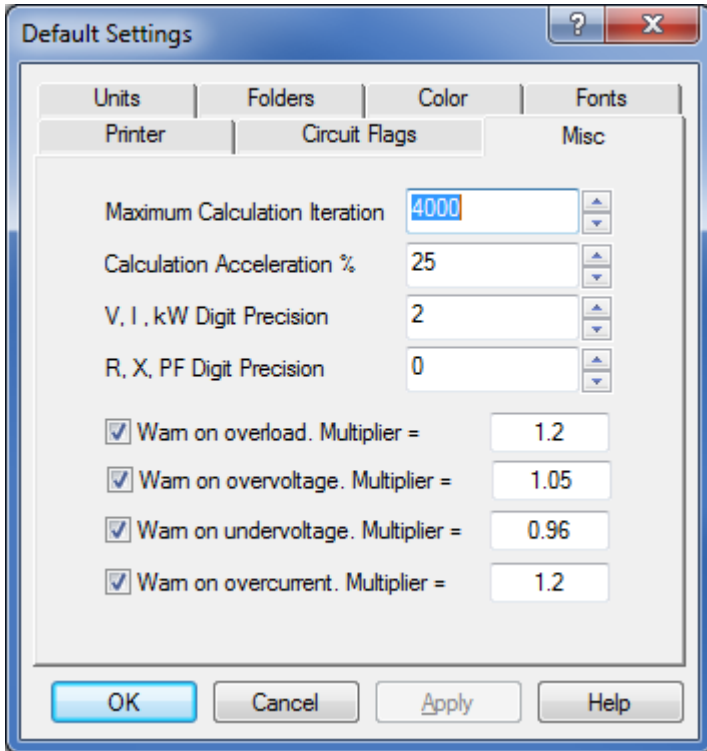

Maximum Calculation Iteration - the calculation must complete before this limit is reached.

Calculation Acceleration- optimum value to speed-up calculation. Too high or too low slows down calculation .

V, I, kW Digit Precision - number of decimal digits for voltage, current, kW, kVA, kVAR .

R, X, PF Digit Precision - number of decimal digits for resistance, reactances, power factor and other data.

Warn on overload. Multiplier = - warning displayed for device kW, kVA, kVAR exceeding this value.

Warn on overvoltage. Multiplier = - warning displayed for device voltage exceeding this value.

Warn on undervoltage. Multiplier = - warning displayed for device voltage below this value.

Warn on overcurrent. Multiplier = - warning displayed for device current exceeding this value.

This settings page is available as default setting for PowerNet (Edit/Default settings menu) as well as individual circuit settings which can be set separately for each circuit file(Circuits/Properties menu).

End User License Agreement

PowerNet is a "try-before-you-buy" software product. This means:

1. All copyrights to PowerNet are exclusively owned by Megasys Software.
2. Anyone may use this software during an evaluation period of 30 days. If you wish to continue to use PowerNet after this period, you must register.
3. There are 2 basic types of licenses issued for PowerNet, these are:
 - a. A single computer USAGE license. The user purchases ONE license to USE PowerNet on ONE computer.
 - b. A Multiple USAGE license. The user purchases a number of USAGE licenses for use, by the purchaser, the purchaser's employees or accredited agents, on the same number of computers.

Once registered, the user is granted a non-exclusive license to use PowerNet on as many computers as defined by the licensing terms above according to the number of licenses purchased, for any legal purpose. The registered PowerNet software may not be rented or leased, but may be permanently transferred, in its entirety, if the person receiving it agrees to the terms of this license. If the software is an update, the transfer must include the update and all previous versions.

4. The license key received after registration of PowerNet may not be distributed. If your license key is found to be published anywhere, your license for using PowerNet will be terminated.

5. The PowerNet unregistered copy, may be freely distributed, with exceptions noted below, provided the distribution package is not modified.

a. No person or company may charge a fee for the distribution of PowerNet without written permission from the copyright holder.

b. The PowerNet unregistered copy may not be bundled or distributed with any other package without written permission of the copyright holder.

c. Hacks/crack, keys or key generators may not be included on the same distribution.

6. PowerNet is distributed AS IS. No warranty of any kind is expressed or implied. You use this software at your own risk. The developer will not be liable for data loss, damages, loss of profits or any other kind of loss while using or misusing this software.

7. You may not use, copy, emulate, clone, lease, sell, modify, decompile, disassemble, otherwise reverse engineer, or transfer the licensed program, or any subset of the licensed program, except as provided for in this agreement. Any such unauthorized use will result in immediate and automatic termination of this license and may result in criminal and/or civil prosecution.

8. There are NO additional license fees, except the cost of registration, associated with creation and distribution of help documents. Legally registered users may use their copies of PowerNet to produce help documents in any supported format and to distribute those documents free of any additional royalties related to PowerNet.

9. Installing and using PowerNet signifies acceptance of these terms and conditions of the license.

10. If you do not agree with terms of this license you must remove the files of the product from your storage devices and cease to use it.

All rights not expressly granted here are reserved by the copyright holder.

How To Order

You can order PowerNet online through our secure website. Your payment will be processed by well known payment service provider PayPal. You do not need to be a member of PayPal, they will process Visa or Mastercard and accept payments in different currencies (US Dollar, Australian Dollar, Euro, Pound Sterling, Canadian Dollar, etc).

Once your order is complete, your [license key](#) will be immediately sent via email to unlock the software for use.

The final cost for PowerNet depends on what type of [license](#) and how many copies of that license you are ordering. The latest pricing information is available on our [Web site](#).

The quickest way to order is by selecting *Help/Buy Now* from the PowerNet menu. Or you can simply visit the Megasys Software web page and place your order:

<https://www.megasyssoftware.com/products.php>

Copyright © 2010-2012 Megasys Software

License Key

As soon as your [order](#) for PowerNet is complete, you will receive a license key, which should be entered into the program to unlock it for use.

To apply your license key:

1. Select the license key in your order confirmation e-mail, and press Ctrl+C to copy it to the Clipboard.
2. Run PowerNet.
3. Choose Help|Enter License Key from the menu.
4. In the dialog-box, click the Paste button to insert your license key.
5. Click the OK button and then restart PowerNet.

You are strongly advised to save your order confirmation e-mail for future reference.

Please do not distribute your license key and do not let anybody copy it. Otherwise, as stated in the [license agreement](#), if your key is published anywhere, your license for using PowerNet will be terminated.

Lost your key?

If, for any reason, you have lost your license key, just [contact us](#) and we will resend it to the e-mail address you used when registering.

Feedback

For any questions, comments, or suggestions, please contact our technical support service at:

support@megasyssoftware.com

While describing the problems you have found in PowerNet, please provide us with the following information:

- PowerNet version.
- Your Windows version.
- Hardware details
- Sequence of your actions that caused the problem.
- As many details related to the problem as possible.

Before requesting technical support, please make sure you are using the latest version of PowerNet .
Information on the latest releases can be found on the Web site at:

www.megasyssoftware.com

Copyright © 2010-2012 Megasyss Software

Upgrades

If you are a legally [registered user](#) of PowerNet, you have the right for free upgrades to any newer minor version (for example, from 1.0 to any 1.x version). Or, you have the right for free upgrades to any newer major version (for example, from 1.x to 2.x, 3.x, 4.x, and so on) in case if the period of one year since your order date has not yet elapsed.

In other cases, you have the right for a 50% discount from our current price for an upgrade to any newer major version of PowerNet.

For more information about recent releases, please visit our Web site at:

www.megasyssoftware.com

Copyright © 2010-2012 Megasys Software

Index

A

Abbreviations, 26
admittance, 52
analysis, 54

B

bug report, , 73
Bus, source, 38,

C

Cable, 39,
Calculation, 53, 69
Capacitor, 41,
circuit
 calculation, 4, 55
 definition, 22
 diagram, 4
 fault, 56
 menu, 10
 options, 68
 properties,
 report, 62
 settings, 68,
 toolbar, 18
circuit analysis, 54
circuit breaker, 48
Connecting Lines, 29

D

Data Tip, 59
Database, 37
device, 23
 data, 4
 menu, 11
 Properties, 35, 36
Distribution Board, 51, 63

E

Edit Menu, 8
email,
errors, , 53, 73
exit,

F

Fault, 56
file menu, 7
files
 managing, 7, , , , , , ,
fuse, 48

G

- Generator, 42,
- getting started, 3
- graphics
 - elements, 32
 - menu, 13
 - operations, 33
 - properties, 34
 - toolbar, 19

Grid, 25

H

Help, , 15, ,

I

- Impedance, 52,
- Induction Motor, 45

K

keyboard shortcuts, 5

L

- labels, 31
- License Agreement, 70
- license key, 71, 72
- Lines, 25
 - drawing, 29
 - moving, 28
- Load, 44,

M

- MCC, 46
- Motor Control Center, 46
- Motor, Induction, 45,
- Motor, Synchronous,
- mouse techniques, 6

N

New Keyword1,

O

ordering, 71

P

- position labels, 31
- power factor correction,
- printing and print preview, , , , , , , , 67
- Protective Device, 48,

S

- scroll bars,
- send email,
- Source Bus, 38,
- status bar, ,
- symbol set toolbar, 21
- symbols, 24
 - block, 6

- copy and paste, 30
- duplicating, 30
- moving, 28
- properties,
- toolbar, 20

Synchronous Motor, 46

T

- toolbar,
 - circuit, 18
 - graphics, 19
 - main, 17
 - symbols, 20

transformer, 49,

transmission line, 51,

U

units, 63

upgrades, 74

V

vector display, 61

view menu, 9

W

Windows Menu, 14,